

As the name suggests, this small device will allow you to use gravity, under airbrake control, to drive a simple machine.

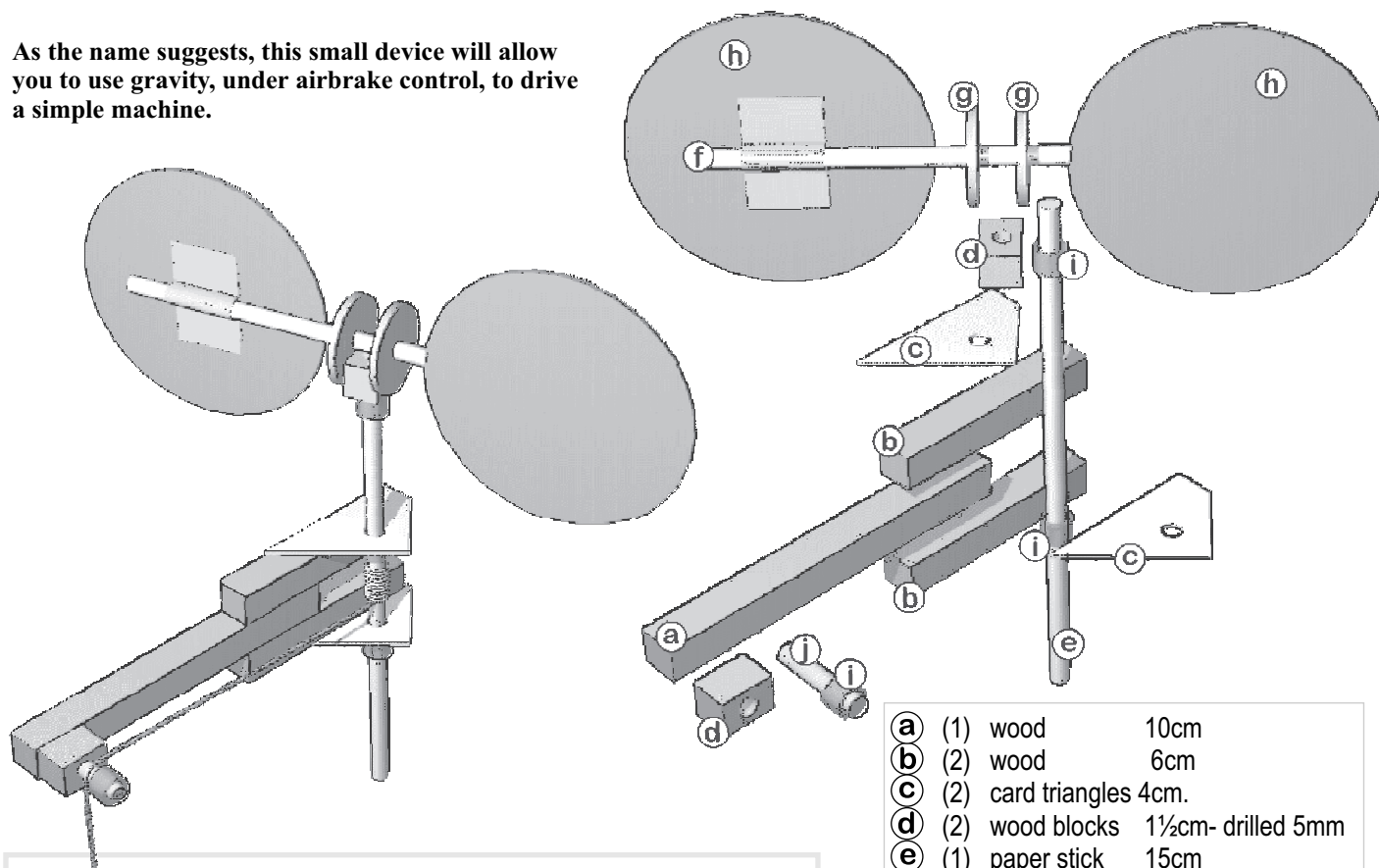

(a)	(1) wood	10cm
(b)	(2) wood	6cm
(c)	(2) card triangles	4cm.
(d)	(2) wood blocks	1½cm- drilled 5mm
(e)	(1) paper stick	15cm
(f)	(1) paper stick	15cm
(g)	(2) card discs	25mm dia.
(h)	(2) thin card sails	about 8cm square
(i)	(3) PVC stoppers	
(j)	(1) dowel	2cm
		thread - at least 1m.

- Cut the 3 pieces of wood for the frame and glue them together. Overlap the wood about 3cm.

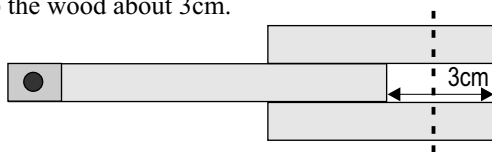

- Fix card triangles so that the holes line up across the gap in the frame. (This is to prevent the thread jamming in the frame when fully wound). The triangles will project over the end of the frame so cut off whatever sticks out once the glue is dry.
- Fix the drilled block to the other end of the frame. This forms the mount for our 'pulley'. Once set, put the short dowel in the hole and add a PVC stopper to that dowel.
- Push other drilled block onto the top end of the shaft (paper stick). If it's loose then it may be glued. If it's a tight fit, then just leave it as it is.
- Slide the two card discs onto the second paper stick until they are approx. 1cm apart and at the centre of the stick - do NOT glue.
- Now glue these discs to the drilled block that is on the shaft. Do not allow any glue to get onto the paper stick that passes through the discs. This stick will need to rotate.
- Fasten the thin card squares to the ends of the paper stick as shown. You may leave them square, position them as diamonds, or cut them into another simple shape like a circle. It is important that you do not remove too much card. (Why?)
- Add a stopper to the shaft and slide it into the frame. Adjust the position of the stopper so that the shaft can rotate without the card 'sails' touching the frame.
- Fasten the thread to the shaft between the triangles. You may add a paper clip hook to the end of the thread.

OPERATING THE GRAVITY MOTOR

Wind the thread around the shaft, attach a small weight to the end of the thread, and hold the motor in its upright position. Pass the thread over the dowel pulley and let the weight fall - the shaft should rotate.

The speed of rotation can be controlled by adjusting the sails. With the cards vertical, the air resistance will slow the fall considerably, (if you haven't cut them too small!). Turning the horizontal paper stick through 90° will reduce this resistance and the weight will fall more quickly. Angles between 0° and 90° will give a proportional speed reduction.

Note that the pulley allows the direction of the force to be altered. Gravity pulls the weight down vertically but the thread exerts a horizontal force on the shaft. If you wish to have the shaft rotating horizontally, then turn the whole motor through 90°.

You can drive simple machines using this device. The system works particularly well with rotating optical toys such as the zoetrope. (See zoetrope project).