

ES	TECHNOLOGY	Knowledge & understanding	Needs	Resources	Processes
	TECHNOLOGY	Skills in designing & making	Preparing	Carrying out	Reviewing
	SCIENCE	K & U - Energy and forces	Properties of energy	Conversion of energy	Forces <i>push/pull, gravity friction, air resistance</i>
	SCIENCE	K & U - Earth & space	Materials from Earth	Changing materials	

The helicopter-like friction drive is an interesting machine which you might feel ought not to work. The discs are very smooth and are not pressed together, and yet the transfer of motion is very precise. Only gravity, ie. the weight of the vertical shaft plus the small disc, keeps the two wheels in contact. You will find that the device only works one way up - as soon as you turn it over the wheels separate and the drive disconnects.

As shown the end of the drive shaft is bare, ie. it isn't connected to any source of power. To make it work you at least need to turn it by hand, so the shaft could be bent into a crank. Now if you put the large disc onto a flat surface, you will find that you can 'wheel' it along and the device will work. If there were a disc on both ends of the shaft it would become an axle.

The design brief is to combine the drive with a simple vehicle to make an interesting mechanical toy, so that when the vehicle is pulled, or pushed, the right-angle drive operates and some feature is made to revolve.

STAGE ONE

So what is this feature likely to be?

A roundabout?

An advertising banner?

A mouse chasing a cat?

A sailor with his telescope?

Will you need to rebuild the drive mechanism with different proportions, or will you be able to utilise the one shown opposite?

If you increase the weight of the revolving feature you will increase the pressure on the rim of the bigger drive wheel. Will that increase the friction and make the machine more efficient? Or will extra weight make it more difficult to turn? What about problems of air resistance?

STAGE TWO

Make the decisions and build the toy vehicle. Try to build it in such a way that you can make any necessary changes. Try different versions of the special feature, in case one works much better than the others.

This is a toy, so decide how to make it look appealing. Colour? Decoration?

STAGE THREE

Play with the toy. Is it fun? Show it to younger children and ask them to play with it. Do they enjoy playing with it?

Make a drawing of your toy so that someone else could make one for themselves.

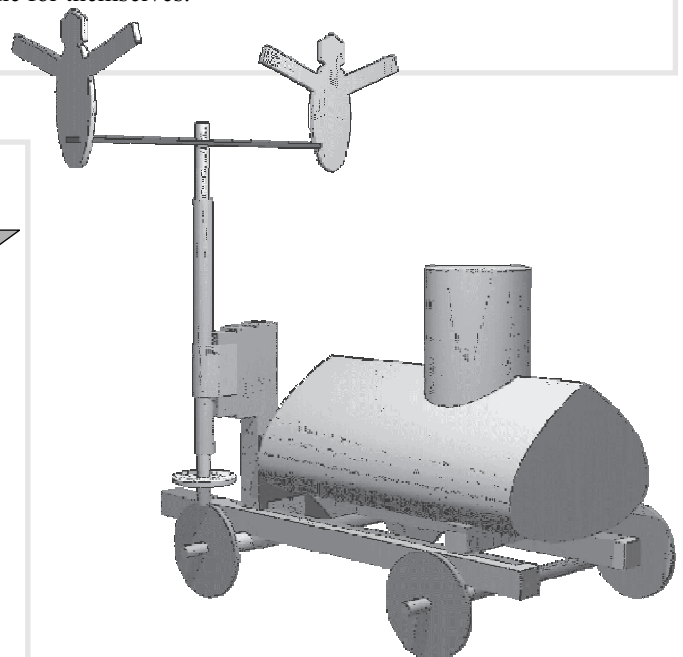

We say above that the drive will not work except the 'right way up'. Now here is a diagram of the moving parts of the drive, without the frame.

Is it the same way up?
Will gravity keep the discs in contact?

The section on the left represents a wind turbine, like the one used in the wind hoist project. (The arrows represent the wind).

Will the star rotate if the wind blows on the turbine?
Why not make one to see if you are correct.