

ES	TECHNOLOGY	Knowledge & understanding	Needs	Resources	Processes
	TECHNOLOGY	Skills in designing & making	Preparing	Carrying out	Reviewing
	SCIENCE	K & U - Energy and forces	Properties of energy	Conversion of energy	Forces
	SCIENCE	K & U - Earth & space	Materials from Earth	Changing materials	<i>levers, gravity, friction</i>
	SS&T	K & U - People in the past	Change and continuity		

The barrow introduces the important concept of independently turning wheels on the same axle. Without this capability it is not possible for a vehicle to change direction of travel without one wheel having to slide rather than roll. As the diagram (bottom right) illustrates, when a vehicle turns, the wheels on the outside of the curve have to travel further (and so go round more times) than the wheels on the inside of the curve.

The technology of this hand cart is fundamental to almost any road vehicle you may wish to design and make. Our model still has a few problems that need to be solved.

A. If the barrow is full of, let us say, turnips, how do we get them out? We could lift them out one at a time but we couldn't tip them out without completely up-ending the barrow. What's needed is for one side of the box to be either removable or hinged. Then we could tip out the contents.

B. These contents are going to get very wet if it rains, or if they are very light they may well blow away. So we also need a fitting cover for protection.

C. When the handles or shafts are released they fall to the ground. Now if the ground is muddy, the ends of the shafts will sink in and get very messy. Of course, as these handles go down the whole barrow tips, so if it's contents are piled high they may fall out.

You are asked to design modifications to your barrow to solve one or more of these problems. You do not need to make another barrow, but you may find it easier to make a new box rather than alter the existing one. It depends on your design solutions.

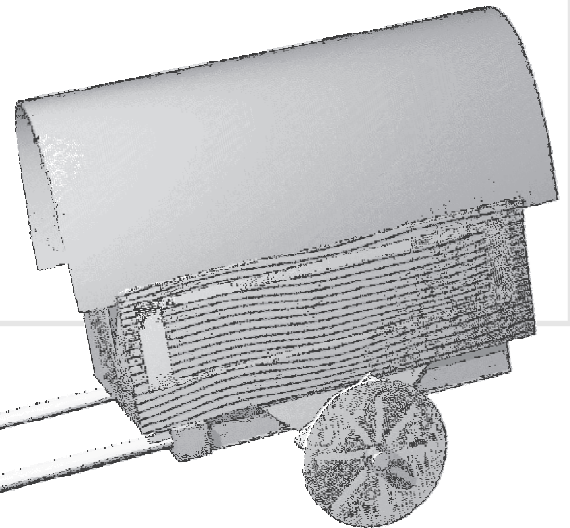

The position of the axle makes a difference to the load on the shafts.

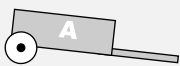

Barrow A - Like a wheelbarrow, the handles carry about half the load, so it would quite hard to lift.

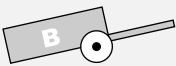

Barrow B - Here you have to lift the full load, by pressing down on the handles. If you're not heavy enough you'll stay in the air!

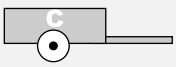

Barrow C - The barrow is balanced. The load on the handles will be very little.

