

A set of useful items for table or desk. The pencil-holder keeps a pencil from rolling off the table and the card-holder displays a card.

Ideal for the weather table or the colour table.

Both items could be made from precut wood, or the opportunity could be taken to allow children to cut their own.

#### CARD HOLDER

- Cut (or find) the pieces of wood needed.
- Very young children (nursery) should 'build two walls', vertically, getting them as flat as possible.
- P1 or P2 children should build the 'walls' flat on the table.
- Glue the walls to the card, no more than 1cm apart.

#### PENCIL HOLDER

- Cut (or find) the wood needed.
- Children could drill the hole or a hole could be provided.
- Glue the parts to the base card and decorate as required.

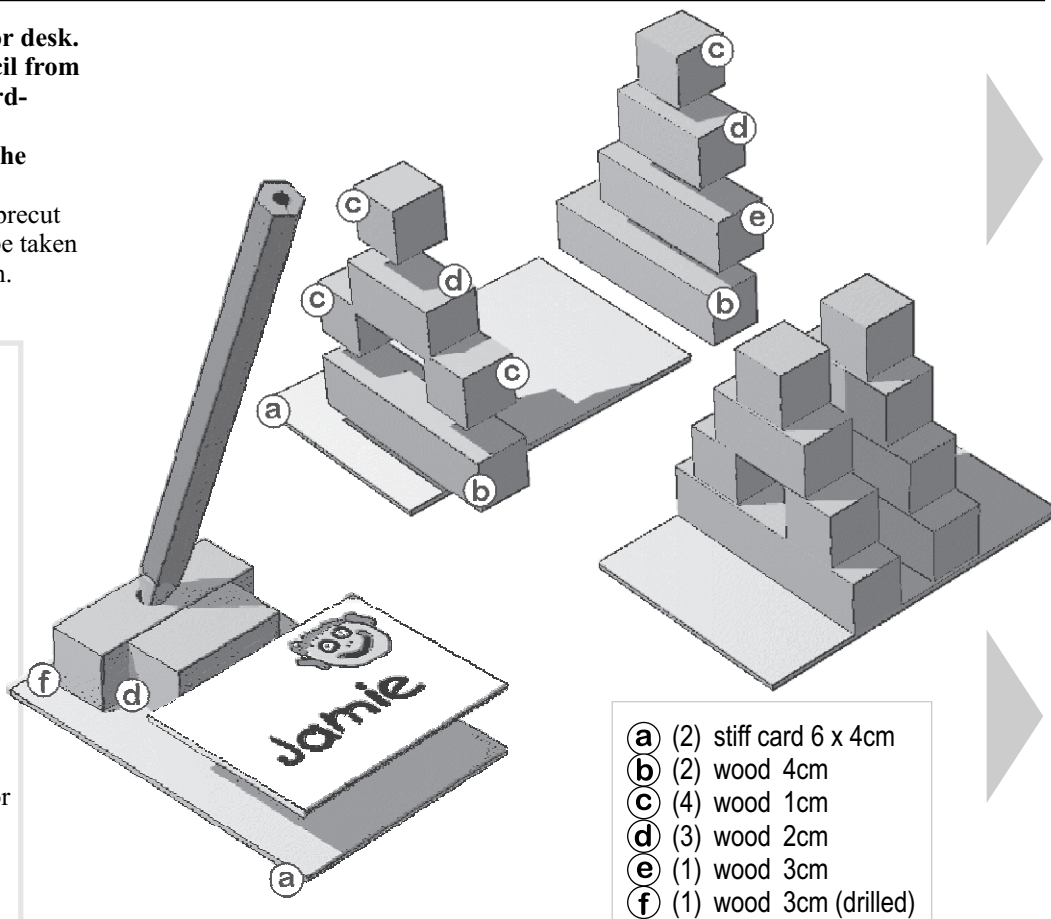

## 'GRIPS & GRABS'

#### TWEEZERS

- Almost instant to make. Cut the ends off a lolly stick (4cm?)
- Glue them together then sandwich between two complete lolly sticks. Use PVA, but wrap a length of masking tape around to hold the parts together while the glue sets.
- Before the glue sets, press the open end against the table to make sure the ends are the same length.

#### GRAB

- Pre-punch the lolly sticks with a hole punch (or drill).
- Assemble the lolly sticks with paper fasteners as shown. Remember that a lolly stick is either always on top or always underneath at the 3 pivot points.
- Fit card 'grips. Two on one end, one on the other. Bend the '2' outwards a little so that the single fits between.

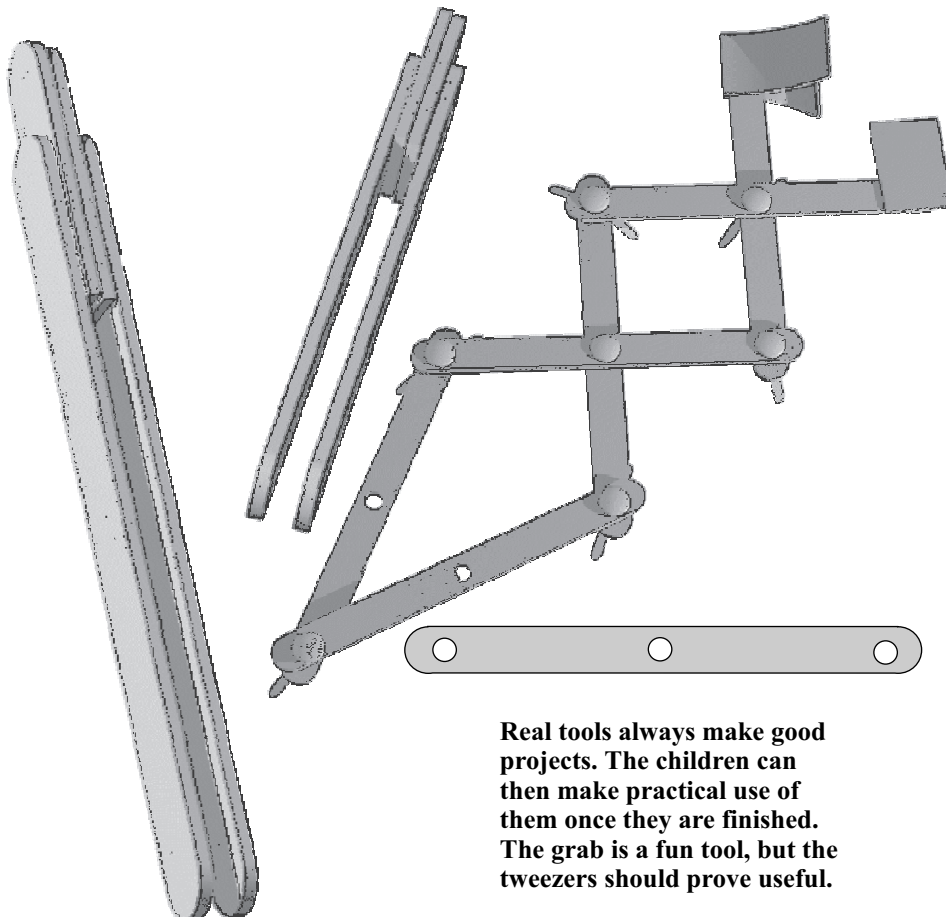

Real tools always make good projects. The children can then make practical use of them once they are finished. The grab is a fun tool, but the tweezers should prove useful.