

Foreword	1
Introduction	3
Planning projects	4
Working drawings	6
Skills progression	8
Materials - wood	9
- card	10
- prices	12
Basic tool kit	13
Adhesives	14
Electricity	17
Saws and sawing	18
Holes in - card	20
- wood	21
Frames and chassis	22
Cuboid frames	23
Simple steering systems	24
Pivots and hinges	25
Wheels and axles	26
Pulleys	28
Gears	30
Cranks and winders	31
Boxing clever	32
Adjustment	34

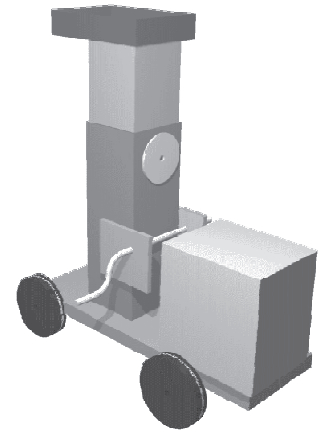

SUPPORTED DESIGN PROJECTS

Key to the projects		36
Duck under the bridge	<i>Footbridge</i>	38
Marble Ramp	<i>Marble game</i>	38
Card & pencil holders	<i>Combined holder</i>	40
Grips & grabs	<i>Magnetic pick-up game</i>	40
Red-nose rocker	<i>Seesaw</i>	42
Monster truck	<i>Land yacht</i>	42
Simple crane	<i>Wishing well</i>	44
Barrow	<i>Improved barrow</i>	46
Crane	<i>Mobile crane</i>	48
Land yacht	<i>Propeller driven vehicle</i>	50
Chatterbox	<i>Cherry picker</i>	52
Derrick	<i>Derrick with brake</i>	54
Wind Hoist	<i>Stand & brake for hoist</i>	56
Friction drive	<i>Pull-along toy</i>	58
Trip hammer	<i>Rhythm machine</i>	60
Air pump	<i>Skirly-whirly</i>	62
Traction trebuchet	<i>Throwing machine</i>	64
Kaleidoscope	<i>Electric kaleidoscope</i>	66
Gravity motor	<i>Time machine</i>	68
Helter skelter	<i>Marble run</i>	70
One-string fiddle	<i>Tuned musical instrument</i>	72
Steelyard	<i>Sorting by weight</i>	74

FOCUSSED PRACTICAL PROJECTS

Mask	76
Little ships	77
Waving puppet	78
Dolls' house furniture	79
Mr. Walker	80
Train	81
Pop-up card	82
Carousel	83
Onager or mangonel	84
Rod puppet	85
Flapper	86
Go-kart	87
Cantilever bridge	88
Double windmill	89
Periscope	90
Weaving loom	91
Hydraulic unit	92
Small boat	93
Zoetrope	94
Phenakistoscope	95
Board game	96
Tabscorer	97
Girders	98